



B&W Trailer Hitches
 1216 HWY 224 / PO Box 186
 Humboldt, KS 66748
 P:620.473.3664
 F:620.473.3766

NOTE: *we recommend reading instructions before beginning the installation.*

Frame to Rail Bracket Kit 3205 Installation Instructions For use in conjunction with 3200 Universal Rail Kit.

Model 3205

Call or Email us for Installation Support
 hitches@turnoverball.com www.turnoverball.com

TOOLS REQUIRED FOR 3200 & 3205 INSTALLATION				
1" DRILL BIT	3/16" DRILL BIT	17/32" DRILL BIT	3/4" SOCKET AND WRENCH	100 lb-ft TORQUE WRENCH

3205 HARDWARE KIT	QTY:
A - Left rear bracket	1
B - Left front bracket	1
C - Right rear bracket	1
D - Right front bracket	1

3200 HARDWARE KIT	QTY:
1 - Carriage bolt 1/2-13 x 2"	10
2 - Mounting rail	2
3 - Slotted spacer	10
4 - Block spacer	2
*5 - Short mounting bracket	2
6 - Flat washer	10
7 - Lock washer	18
8 - Finish nut	18
9 - Knurled bolt	8
*10 - Long mounting bracket	2
11 - Carriage bolt 1/2-13 x 4-1/2"	2
12 - Tube spacer	2
13 - Fish wire	2

* = items not used in this installation

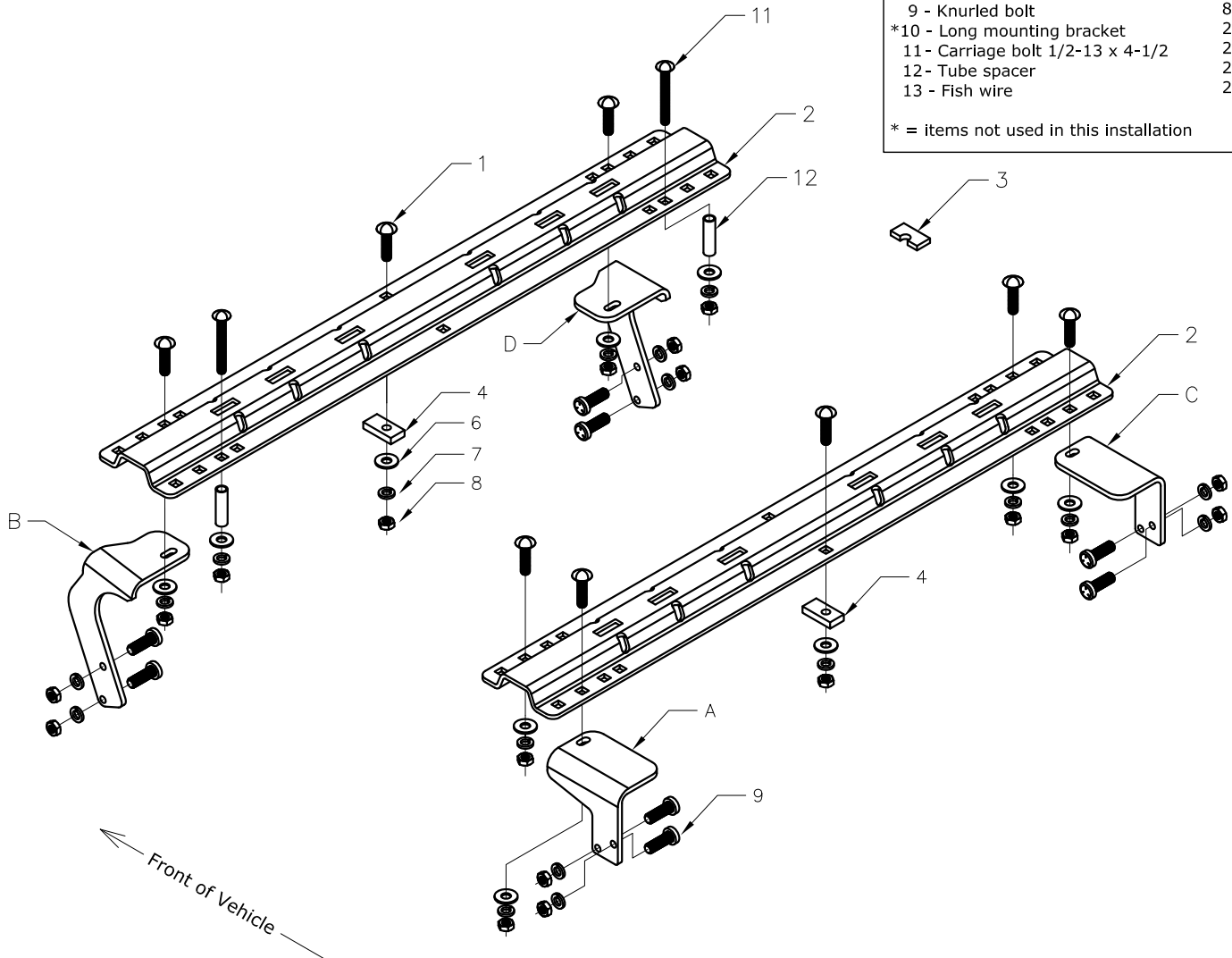

Read these instructions completely and also pages 1 & 2 of 3200 universal rail instructions before beginning installation. Failure to do so could result in significant vehicle damage.

CAUTION:

Check for obstructions below the truck bed before drilling. Failure to do so could result in damaged fuel or brake lines, structural members, etc. B&W does its best to communicate tow vehicle manufacturer changes; however, it is ultimately the responsibility of the installer to prevent damage due to installation.

WARNING:

Do not install on a truck with a 5'6" long bed unless provision has been made to prevent the trailer from hitting the cab of the truck.

A tube spacer and 4 1/2" carriage bolt will be used to attach through forward bed rail (Row B). It may be necessary to shorten the tube spacer to ensure that the hitch rail lays evenly across the corrugated truck bed surface. Use a straight edge laid across the bed surface to determine if the tube is the correct length for your truck. The tube can be cut or ground to the exact height.

Rib neck bolts will need to be pulled through access holes in frame with supplied pull wire (see below). Do not drill through both walls of frame. Drill only through wall of frame to which bracket is mounted. Use provided slotted spacers as needed above or below truck bed to make up for the corrugation space.

For row B, drill through Bed Sill with 17/32" drill. Open up hole through truck bed only with 1" dia. drill. Drop tube spacer through hole in truck bed to avoid crushing Bed Sill when torquing 4-1/2" carriage bolt.

1. Each mounting bracket must be attached to the truck frame with two 1/2" bolts or welded as specified below.

2. Align the brackets with the carriage bolts that come through the mounting rails and truck bed and use the mounting brackets as a template to mark two holes to be drilled through the outer face of the truck frame. Be very careful not to pinch electric or fuel lines with the brackets. The electric fastener at the driver side rear bracket may need rotated to make room for the bracket.

3. Use a 17/32" drill bit to drill all frame holes.

4. Use a fishwire supplied with the 3200 kit to pull a rib necked bolt through a larger access hole into the frame and out through the drilled frame and bracket hole. The threads of the bolt will be pointing outward through the bracket.

5. When the brackets are in place add a lock washer and finish nut to each bolt and torque to 85 ft-lbs.

6. *Due to tubular frames having thinner walls than channel frames, extra caution needs to be used when mounting with the welding option.

7. Check periodically to make sure all hardware remains tight.

USE ASSEMBLED PATRIOT BASE TO POSITION FRONT RAIL.

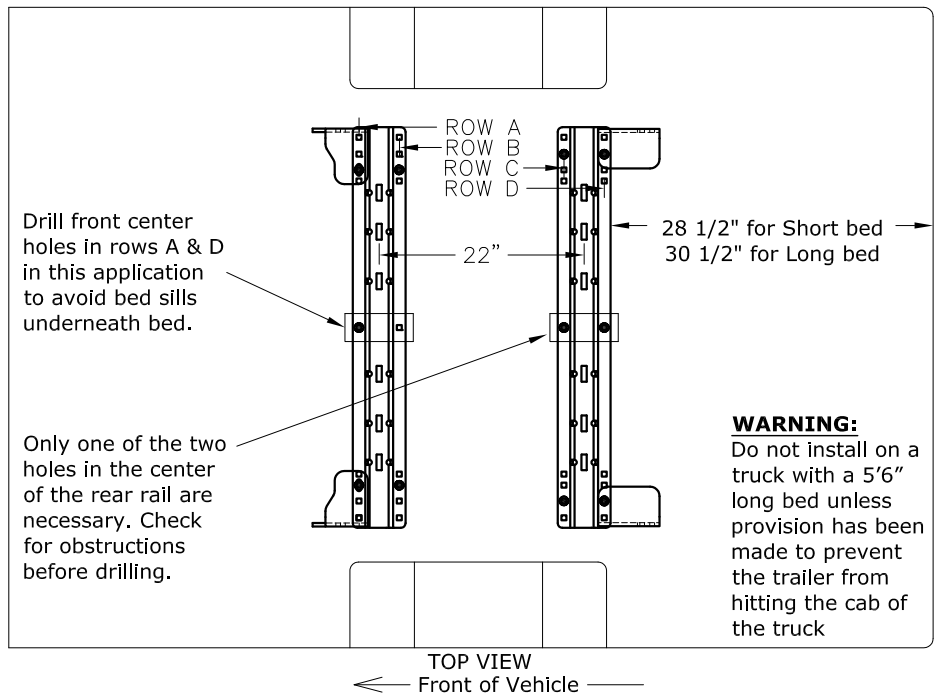

KING PIN CENTER APPROX. 1-1/2" FOWARD OF AXLE CENTER

AXLE CENTER

PATRIOT BASE

BED SILL

ACCESS HOLE

USE PROVIDED TUBE SPACERS AND 4-1/2" CARRIAGE BOLTS TO ATTACH THROUGH BED SILL

DRILL HOLES

DRILL HOLES

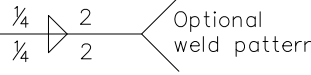

VIEW OF DRIVER SIDE

ACCESS HOLE

← Front of Vehicle →

WARNING:

Do not install on a truck with a bed less than 6' long unless provision has been made to prevent the trailer from hitting the cab of the truck