



TRAILER HITCHES

Turnover Ball™ Gooseneck Hitch Installation Instructions

Model 1199R

Ford (1999 and newer)
3/4 & 1 Ton, Super Duty
F-250 and F-350

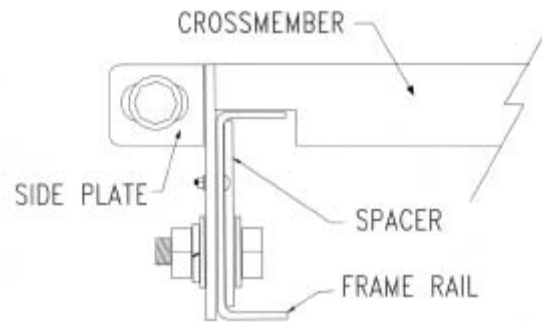
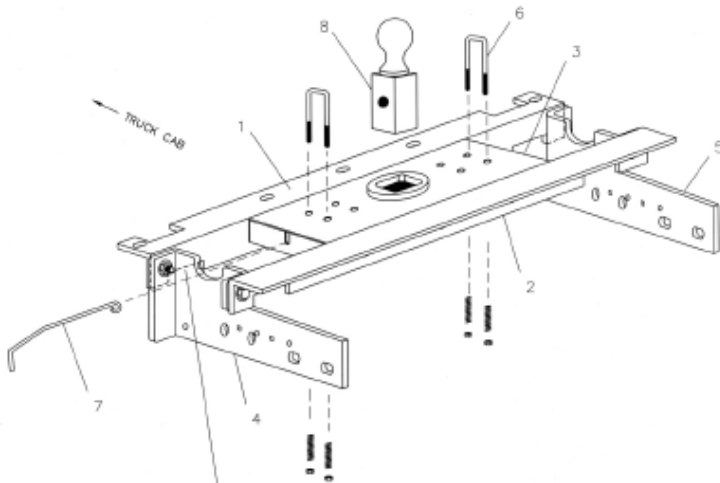

NOTE: FRONT CROSS MEMBER IS ORIENTED SO THAT SHALLOW NOTCH IS DOWN AGAINST FRAME ON FULL SIZE BEDS AS SHOWN HERE (49" BALL LOCATION). SHORT BEDS (46" BALL LOCATION) REQUIRE THAT THE FRONT MEMBER BE TURNED SO THAT THE DEEP NOTCH IS DOWN AGAINST THE FRAME.

Parts List

- 1 - Front Crossmember (#11996)
- 2 - Rear Crossmember (#11997)
- 3 - Center Section (#800R)
- 4 - Left Sideplate (#11994L)
- 5 - Right Sideplate (#11994R)
- 6 - Safety Chain Brackets (#1600)
- 7 - Latch Pin Handle (#HR2002)
- 8 - Turnover Ball (#2000)

Hardware Kit

- 1 - 5/16" X 1 Carriage bolt
- 1 - 5/16" hex lock nut
- 1 - 5/16" f at washer
- 1 - 5/16" lock washer
- 10 - 1/2" X 1 1/2" bolt
- 10 - 1/2" hex nuts
- 10 - 1/2" lock washers
- 14 - 1/2" f at washers
- 4 - 3/4" X 2 1/2" bolts
- 4 - 3/4" hex nuts
- 4 - 3/4" lock washers
- 8 - 3/4" f at washers
- 2 - 1/4" X 3" X 5" spacers
- 2 - 1/2" long pipe spacers

B&W Custom Truck Beds, Inc.
1216 HWY 224 / PO Box 186
Humboldt, KS 66748
(800) 248-6564
(620) 473-3664
Fax: (620) 473-3766

Call or Email us for Installation Support

hitches@turnoverball.com
www.turnoverball.com

BEFORE INSTALLING OVERHEAD LIFTING DEVICE

An overhead-lifting device, such as chain falls, engine hoist, or cable come-along, can be used to lift the center section of the hitch in place. Lower a loop of rope or chain through the 4" hole in the truck bed floor and attach it to the latch pin in the round hitch receiver tube in the center section. Use the lifting device to raise the center section until the round hitch receiver tube that protrudes from the center section fits in the 4" hole in the truck bed floor. Maintaining upward pressure may facilitate fastening the crossmember to the center section, especially if the truck bed floor has been distorted downward from heavy use. If you use an overhead-lifting device, it should be disconnected before squaring the center section across the frame, installing the sideplates and torquing fasteners.

WARNING

Most trucks have FUEL LINES and/or BRAKE LINES and/or ELECTRICAL WIRES located along the frame rails where B&W Turnover Ball hitches install. Carefully examine the location of fuel lines, brake lines and electrical wires BEFORE INSTALLATION. Be certain you will not damage fuel lines, brake lines or electrical wires when positioning hitch components, drilling holes, tightening fasteners, and lifting and lowering the truck bed.

WARNING

DO NOT invert the ball in the socket when carrying heavy loads on 2 wheel drive trucks. The ball may hit the top of the differential. Remove the ball from the socket before heavy loading. A plug for the socket is available from B&W.

WARNING

On short bed trucks, BEFORE INSTALLING THIS HITCH, check for adequate turning clearance between the front of all of your trailers and the truck cab.

INSTALLATION INSTRUCTIONS

BALL LOCATION:

Two wheel Drive Long Bed	49"	46" - *CANNOT INVERT THE BALL
Two wheel Drive Short Bed	49"	46" - *CANNOT INVERT THE BALL
Four wheel Drive Long Bed	49"	46"
Four wheel Drive Short Bed	49"	46"
Ball location in front of axle	6-1/2"	3-1/2"

*See Operating Instructions for further explanation

The front angle-iron crossmember is able to accommodate either installation location by turning the angle end-for-end. The notches are made at two different depths; the shallower notches would sit on the frame for the 49 inch location and the deeper notches are used against the frame for the 46 inch location. The rear angle-iron crossmember will work for both locations.

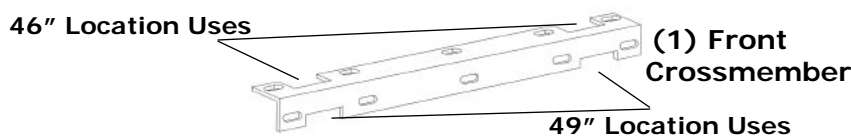

STEP 1

Begin by verifying and measuring the correct hole location in the truck bed floor. Measure from the back end (tail gate end) of the truck bed floor by hooking a tape measure over the end of the truck bed (not including the tail gate) and marking the floor at the correct measurement. Center the measurement between the fender wheel wells. This location is critical to the correct installation of this hitch, so measure, mark and saw carefully. If the truck has a plastic bed liner, you may drill through both, but it is more difficult to accurately locate the midpoint between the fender wheel wells, and to be sure that the bed liner does not move while sawing the hole. Make a 4-inch hole at this location using a four inch hole saw, or by marking a 4 inch circle and cutting it out with a sabersaw equipped with a metal cutting blade.

STEP 2

Remove the heat shield located above the rear axle under the truck bed. The heat shield is attached with sheet metal screws. Replace the front screws after removing the heat shield. The screw head size is 5/16".



STEP 3

Remove the emergency brake cable bracket located on the outside of the driver's side frame and move it out of the way. Knock the mounting stud out of the frame.

STEP 4

Install the two crossmembers. They will be installed by sliding them from inside the wheel well, above the tire, through the gap between the bed and the truck's frame and across until they span the frame rails. The gap between the bed and frame is large enough to allow this, but the gap is partially obstructed by a sheet metal flange (about 1 inch in height) that is hanging down from the bottom of the truck bed floor. (see diagram and photos). A small notch needs to be made in this flange on the **Driver's** side of the truck. Locate front truck bed crossmember. Measure over 1 1/4" from the back of the crossmember and make a mark. This will be the center point for the notch that is needed. Mark a 7/8" wide by 3/8" tall notch.

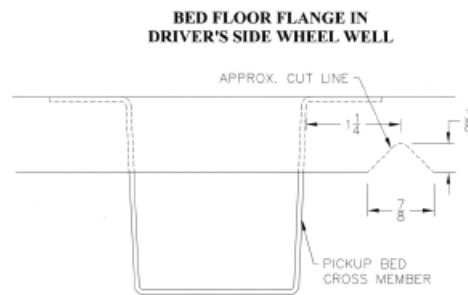

STEP 5

Select the back crossmember (2) with only one set of notches. With the horizontal side up and the slotted side facing the **Front** of truck, position it across the top of the frame rails, between the bed and frame, by pushing it through the opening from the wheel well on the driver's side. When the crossmember is across the frame rails, move it to the rear, up on the higher section of the frame rails. (The notches may not fit down over the frame at the forward location, but will fit properly once it is moved rearward to the top of the hump in the frame). Position it approximately 2 inches behind the hole in the truck bed floor, and use a crescent wrench or channel locks on the slotted side of the crossmember to rotate it down on its long axis, placing the side without slots flush against the truck bed floor. Select the front crossmember (1) with two sets of notches. (Determine which ball location is being installed. (Remember for the 49" location the shallow notches should be oriented down against the truck frame. The 46" location requires the deep notches to be against the truck frame). Position the angle so that the correct notch will seat against the truck frame, hold the angle in an inverted "V" position, and push the angle across the frame using the notch in the bed floor flange for clearance at the apex of the angle. With the angle spanning the frame, move it rearward to approximately 2" in front of the hole in the truck bed floor. The two crossmembers should be approximately parallel, about 9" apart, equally spaced in front of and behind the hole in the truck bed floor.



STEP 6

Raise the center section (3) into position between the crossmembers from beneath the truck, with the latch pin release handle on the driver's side. A lifting device, as described on page 1 will help. The round hitch receiver that protrudes from the top of center section must fit through the hole in the truck bed floor. Fasten the center section to the crossmembers using the six 1/2" x 1 1/2" bolts. Fit these bolts through the slots in the crossmembers using a flat washer against the bolt head and a lock washer under the nut on each. Do not fully tighten at this time.



STEP 7

Square the assembled center section and crossmembers across the frame. Identify the left (4) and right (5) sideplates, by placing the bent angles facing outward and the narrow end to the rear of the truck. Align the sideplate ears between the crossmembers. Insert 1/2" x 1 1/2" bolts through the sideplate ears and the ends of the angle irons. Insert a 5/16" carriage bolt into the square hole in the driver's side sideplate bracket, for attaching the emergency brake cable bracket. Place a pipe spacer between the sideplate and frame and insert a 3/4" X 2 1/2" bolt from inside of the frame rail in the front mounting hole. Insert a 3/4" X 2 1/2" bolt through the 3"X5" frame spacer plate, and install it from the inside of the truck frame rail through the frame hole and the rear hole in the sideplate. The spacer should stand vertically inside the frame and hold the bolt in the proper location even though the shape of the frame hole varies. The spacer will align the side bracket plate with the hole. Once both sideplates are installed, then tighten all four 3/4" bolts on the sideplates to 90-ft. lbs. torque. Tighten all 1/2" bolts on sideplates, angles and center section to 80-ft. lbs. torque. Place emergency brake cable bracket over the 5/16" bolt, install the flat washer, lock washer and nut over the bracket and tighten to 20ft. lbs. torque.



STEP 8

Install the latch pin release handle (7) by inserting the handgrip end of the handle rod from inside the center section through the hole in the endplate. Align the handle loop and the hole in the tab on the end of the latch pin assembly, putting the handle loop on the right side of the tab and bolt together using the 3/8" x 3/4" bolt and lock nut. When properly attached, the center of the handle should be in line with the center of the pin assembly, and the bolt head should be on the loop side, and the nut on the tab side. Tighten the bolt.

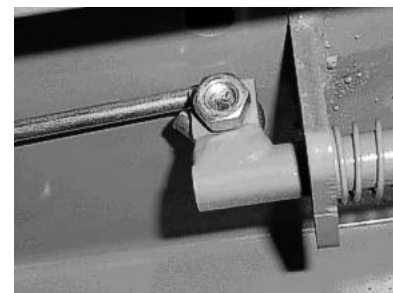
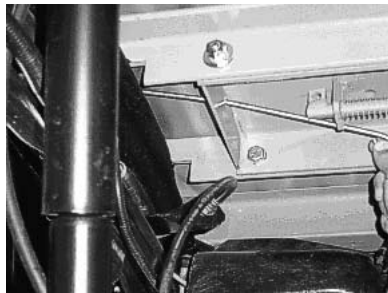

STEP 9

To install the safety chain brackets (6) it is necessary to drill four 1/2" holes through the truck bed floor. Drill the holes from beneath the truck, through the four holes located farthest from the round receiver tube in the center section. This will locate the safety chain brackets (6) in the lowest point of the floor corrugation. Drop a U-bolt through each pair of holes from the top side of the truck bed floor. Place a spring and lock nut on each of the four legs. Tighten the lock nuts until 1/4" of thread extends through the lock nut.



STEP 10

Retract the latch pin by pulling the handle all the way out until it stops and then rotating it clockwise. Place the Turnover Ball (8) in the hitch receiver. Engage the latch pin by rotating the handle counterclockwise. Be certain the latch pin passes through the holes in the Turnover Ball and fully engages through the hitch receiver. Remove and grease the square base of the Turnover Ball.