



B&W Trailer Hitches
 1216 HWY 224 / PO Box 186
 Humboldt, KS 66748
 620.473.3664
 800.248.6564
 Fax:620.473.3766

NOTE: *We recommend reading instructions before beginning the installation.*

Turnover Ball™ Gooseneck Hitch Installation Instructions

Model 1050R

Chevrolet & GMC (1988 - 1998)

1/2 3/4 & 1 Ton, Short Bed Trucks

Chevrolet & GMC (1999 - 2000)

3/4 & 1 Ton Heavy Duty Short Bed Trucks

Old Body Style

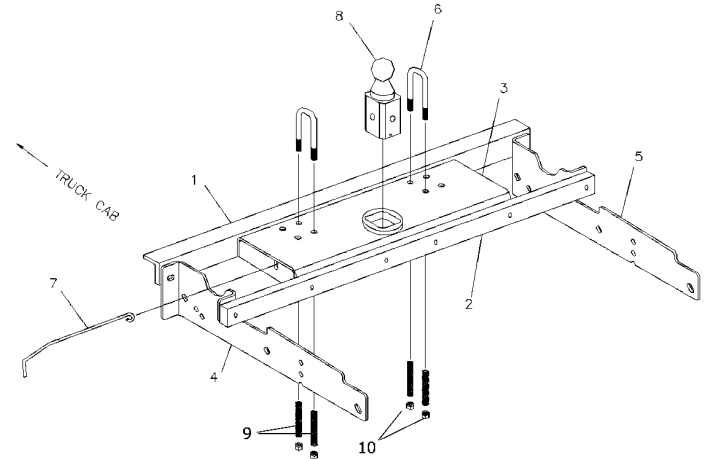

Call or Email us for Installation Support

hitches@turnoverball.com

www.turnoverball.com

- Parts List**
- 1 - Front Crossmember
 - 2 - Rear Crossmember
 - 3 - Center Section
 - 4 - Left Sideplate
 - 5 - Right Sideplate
 - 6 - Safety Chain U-Bolts
 - 7 - Latch Pin Handle
 - 8 - Turnover Ball
 - 9 - Springs
 - 10 - Lock Nuts

- Hardware Kit**
- 15 ea. - 1/2" X 1 1/2" bolts
 - 19 ea. - 1/2" flat washers
 - 15 ea. - 1/2" lock washers
 - 9 ea. - 1/2" nuts
- Safety Chain Kit**
- 2 ea. - 1/2" U bolts
 - 4 ea. - 1/2" Lock nuts
 - 4 ea. - Springs
 - 1 ea. - 3/8"x3/4" Bolt
 - 1 ea. - 3/8" Lock nut

BEFORE INSTALLING OVERHEAD LIFTING DEVICE

An overhead-lifting device, such as chain falls, engine hoist, or cable come-a-long, can be used to lift the center section of the hitch in place. Lower a loop of rope or chain through the 4" hole in the truck bed floor and attach it to the latch pin in the round hitch receiver tube in the center section. Use the lifting device to raise the center section until the round hitch receiver tube that protrudes from the center section fits in the 4" hole in the truck bed floor. Maintaining upward pressure may facilitate fastening the crossmember to the center section, especially if the truck bed floor has been distorted downward from heavy use. If you use an overhead-lifting device, it should be disconnected before squaring the center section across the frame, installing the sideplates and torquing fasteners.

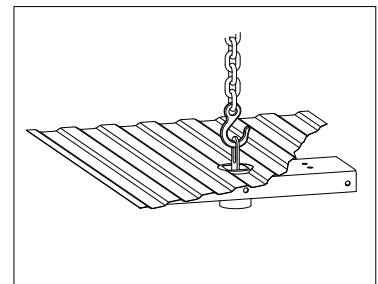

WARNING

Most trucks have FUEL LINES and/or BRAKE LINES and/or ELECTRICAL WIRES located along the frame rails where B&W Turnover Ball hitches install. Carefully examine the location of fuel lines, brake lines and electrical wires BEFORE INSTALLATION. Be certain you will not damage fuel lines, brake lines or electrical wires when positioning hitch components, drilling holes, tightening fasteners, and lifting and lowering the truck bed. The fuel tank vent, located on top of the gas tank, can be easily damaged during the installation of the hitch components. Care must be taken when positioning the front crossmember and center section components.

Warning

On short bed trucks, BEFORE INSTALLING THIS HITCH, check for adequate turning clearance between the front of all of your trailers and the truck cab.

WARNING

DO NOT invert the ball in the socket when carrying heavy loads on 2 wheel drive trucks. The ball may hit the top of the differential. Remove the ball from the socket before loading. A plug for the socket is available from B & W.

INSTALLATION INSTRUCTIONS

STEP ONE

Begin by verifying and measuring the correct hole location in the truck bed floor. Measure from the back end (tail gate end) of the truck bed floor by hooking a tape measure over the back of the truck bed (not including the tailgate) and marking the floor at the **44 1/4"**. Center the measurement between the wheel wells. This location is critical to the correct installation of this hitch, so measure, mark and saw carefully. If the truck has a plastic bed liner, you may drill through both, but it is more difficult to accurately locate the midpoint between the wheel wells, and to be sure that the bed liner does not move while sawing the hole. Make a 4-inch hole at this location using a four inch hole saw, or by marking a 4 inch circle and cutting it out with a sabersaw

STEP TWO

From the underside of the truck, position the two crossmembers (1) and (2), across the top of the frame rails, between the bed and frame. Start with the rear crossmember, (2) which is the solid bar. It is symmetrical, so it doesn't matter which end goes to the driver's side. From behind the differential, raise the passenger side end of the crossmember up over the frame rail and slide it through until the driver's side can be raised up over that side of the frame. Push the crossmember rearward until it is against the bed crossmember that is directly above the truck's axle. Now position the front angle iron crossmember across the frame, with the slotted leg vertical, the horizontal leg at the top, and the slotted side toward the rear of the truck. Place the angle parallel to the bar, about 9 inches apart, as shown in the diagram.

STEP THREE

Select the drivers side – side plate (4) (see diagram) and attach the rear slotted tab to the end of the rear crossmember by threading a 1/2" bolt with a flat and lock washer into the threaded hole. Repeat with the passenger side plate. With the center section (3) latch pin mechanism on the driver's side, raise the center section of the hitch up between the crossmembers. Guide the center section on up against the bottom of the floor, inserting the round receiver tube through the 4" hole cut in the floor. Pull the front crossmember back against the center section, Insert three 1/2" x 1 1/2" bolts in the front crossmember and through the front legs of the center section. Place flat washer, lock washer and nut on the bolts. Leave these bolts loose. Thread four 1 1/2" bolts with flat and lock washers into the rear bar from inside the center section. Now install the bolts in the front side plate tabs.

STEP FOUR

Square the hitch across the frame and align two of the sideplate holes with existing holes in the truck frame. Install two 1/2" bolts, flat washers and lock washers on each side. After all fasteners have been installed, torque to 90 ft.-lbs. torque.

STEP FIVE

To install the safety chain brackets, it is necessary to drill four 1/2" holes through the truck bed floor. Drill the holes from beneath the truck, through the 4 holes nearest the round hitch receiver tube in the center section. This will locate the safety chain brackets in the valley section of the bed floor. Drop a U-bolt through each pair of holes from the topside of the truck bed floor. Place a spring and lock nut on each of the four legs and tighten the lock nuts until they are flush with the bottom of the U-bolt.

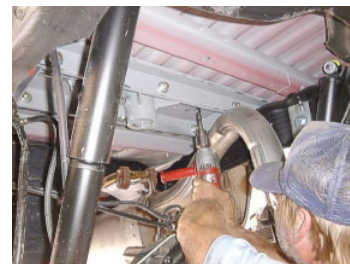

STEP SIX

WARNING: LATCH PIN WILL NOT FUNCTION PROPERLY IF HANDLE IS NOT INSTALLED CORRECTLY.

Install the handle from underneath the truck by inserting it through the slot in the end of the center section toward the driver's side rear tire as shown. Attach the handle to the latch pin as shown with the handle on the "cab side" of the square tab welded to the pin. The head of the bolt must be on the handle side, and the lock nut must be on the tab side. The tab is welded to the pin in an offset position so that the handle will be lined up over the center of the pin. If the handle is fastened to the other side of the tab, the handle will not function properly. When installed correctly the latch pin may be disengaged from the ball by pulling on the handle from the driver's side wheel well and rotating the handle clockwise.

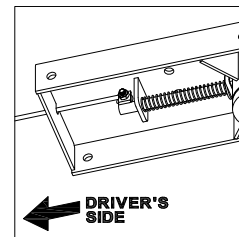
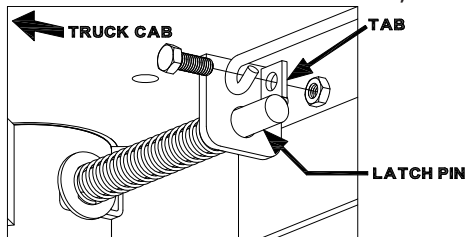
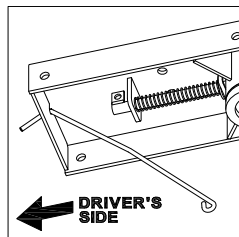

STEP SEVEN

Retract the latch pin by pulling the handle out until it stops and then rotating to the lock out position. Place the turnover ball in the hitch receiver. Engage the latch pin by rotating the handle back to center. Be certain the latch pin passes through the holes in the turnover ball and fully engages through the hitch receiver.